

FLOOR LOCK FOR \varnothing 8 INCH CASTERS - FL-LK-8EH

APPROX WEIGHT: 6 lbs.
DOES NOT INCLUDE WEIGHT OF POWER OR PACKAGING!!!

*** ANY ADDITIONS, DELETIONS, OR OMISSIONS MUST BE CORRECTED ON THIS DRAWING AS THIS DRAWING WILL BE CONSIDERED ALL INCLUSIVE ***
ALL GRAPHICS PROVIDED ARE FOR REFERENCE ONLY. IF CERTAIN DIMENSIONS ARE CRITICAL PLEASE VERIFY THOSE DIMENSIONS WITH YOUR SALESPERSON

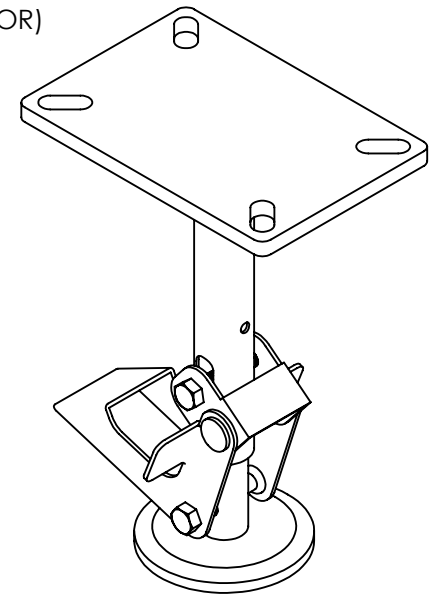
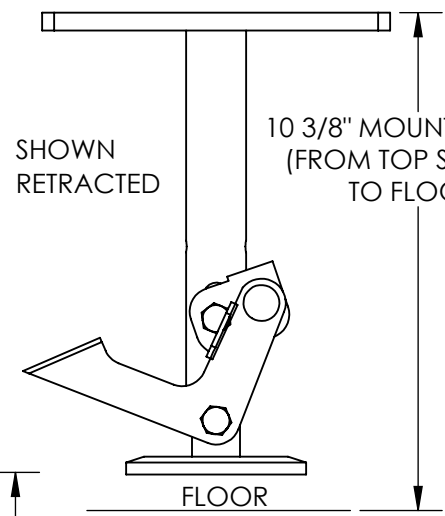
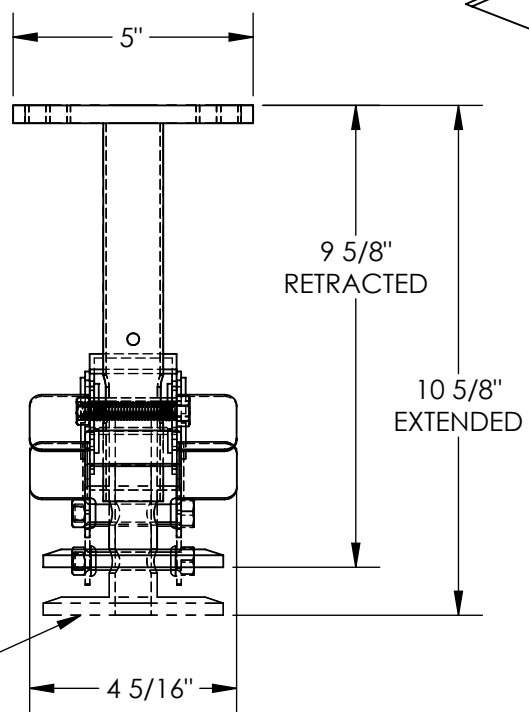
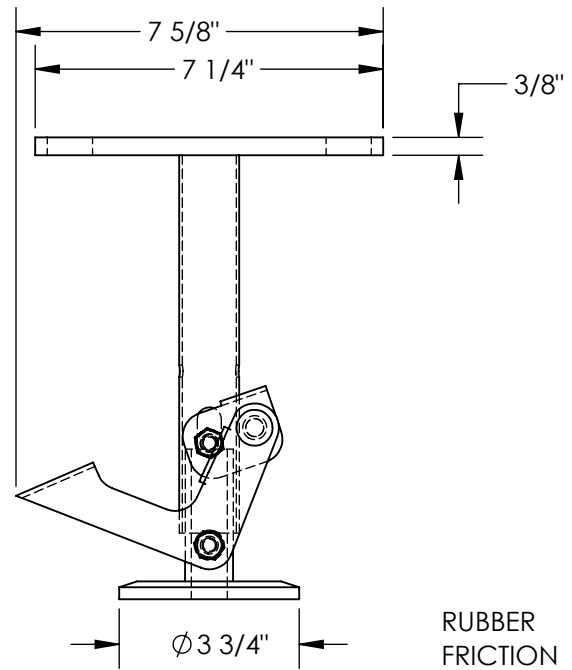
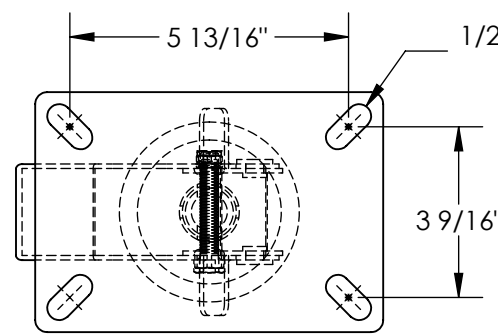

DIMENSION TOLERANCE \pm 1/4"

STANDARD FEATURES

MODEL NUMBER IS FL-LK-8EH
OVERALL WIDTH IS 5"
OVERALL LENGTH IS 7 5/8"
RETRACTED HEIGHT IS 9 5/8"
EXTENDED HEIGHT IS 10 5/8"
MOUNTING HEIGHT IS 10 3/8"
USED WITH \varnothing 8" CASTER
MOUNTING HARDWARE IS NOT INCLUDED

SPECIAL FEATURES

NONE

APPROVAL

I, THE UNDERSIGNED, AGREE THAT THE PRODUCT AS REPRESENTED SATISFIES DESIGN AND DIMENSION REQUIREMENTS. I ALSO ACKNOWLEDGE MY DUTY TO CONFIRM PRODUCT AND INSTALLATION COMPLIANCE WITH ALL APPLICABLE FEDERAL, STATE AND LOCAL REGULATIONS AND STANDARDS.
UNITS REQUIRING APPROVAL DRAWINGS OR MODIFIED ARE NON-RETURNABLE
[] As drawn [] As marked

Signed: _____ Date: _____
Printed Name: _____

LEAD TIME WILL START UPON RECEIPT OF SIGNED APPROVAL DRAWING

DISTRIBUTOR'S NAME:		P.O.#
VESTIL MANUFACTURING		X
DRAWN BY: JWW		W.O.#
DATE: 4/16/2019		X
REFERENCE: X	SCALE: 1:4	SALES: X
QUOTED LEAD TIME: X	QUOTE # X	FILE NAME:
		16-007-453